

COME RILEGARE IL VOSTRO E-BOOK ILLUSTRATO DI 16 PAGINE

- 1 Stampare fronte e retro su un foglio formato A4 (21 x 29.7 cm)
NB: il file pdf ha 2 pagine: pag.1 = fronte; pag.2 = retro

- 2 Piegare il foglio come segue:

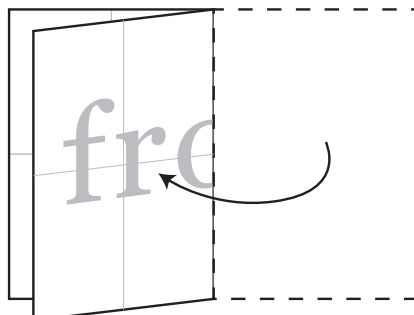

schiacciare bene la piega

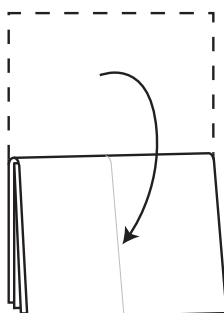
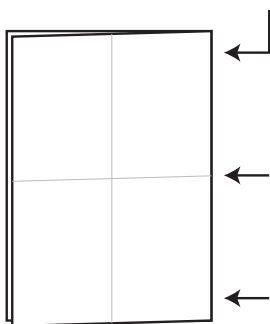

schiacciare bene la piega

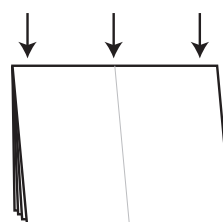

schiacciare bene la piega

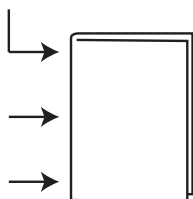
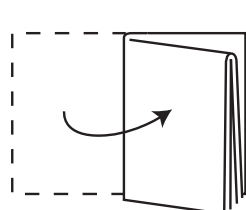

- 3 Cucire il centro della piega con la pinzatrice o con filo forte

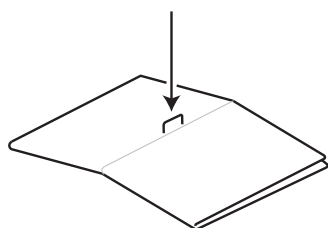

- 4 Tagliare lungo i bordi indicati

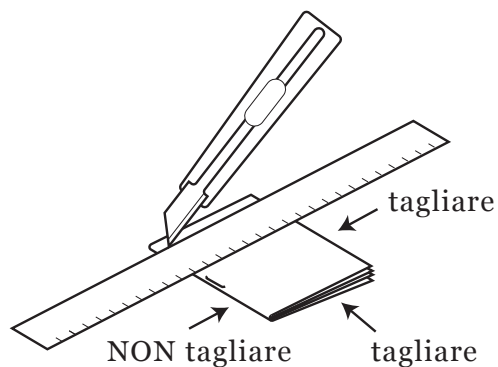

- 5 Aprire il libro